

**EVERISING**  
**EVERISING MACHINE CO.**



No.1 Jingke 1st Road, Nantun District, Taichung 408, Taiwan.  
TEL : +886-4-2350-5300 / FAX : +886-4-2350-5420  
E-mail : evrs@everising.com.tw  
<http://www.everising.com>

# MITRE CUTTING BAND SAW

ISO9001 CE



# MITRE CUTTING BAND SAW

PRECISE CUTTING  
HIGH EFFICIENCY

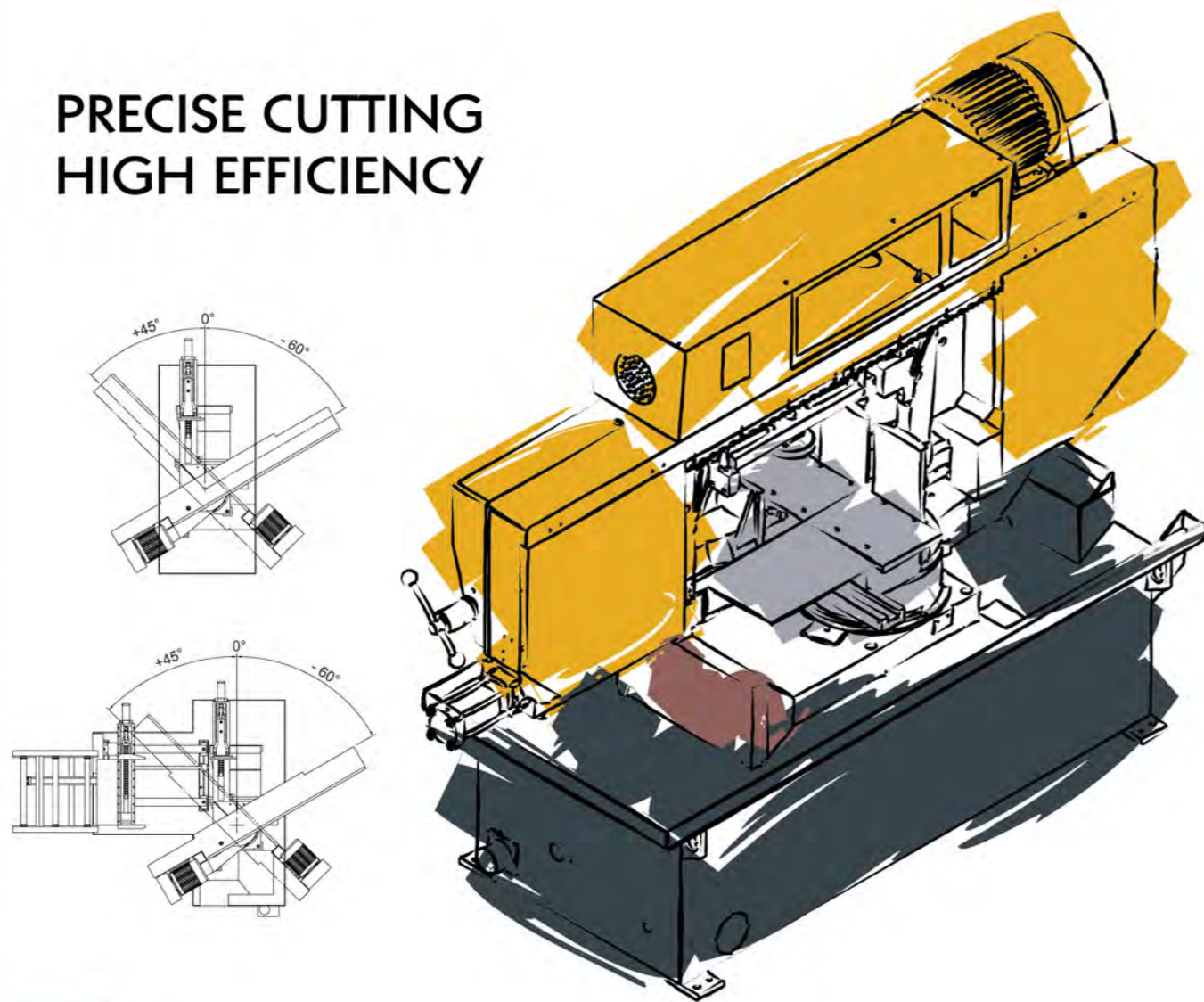

**S**  
SERIES

SEMI / FULLY AUTOMATIC  
PIVOT TYPE MITRE  
CUTTING BAND SAW



# HW

SERIES

HW450/650II  
HW500/900II  
HW700/1100

## HEAVY DUTY MITRE CUTTING BAND SAW

Designed to enhance high efficiency and easy operation, the EVERISING Mitre Cutting Band Saw is a heavy duty double column construction. In addition, its swiveling table design in combination with well-planned control system fully exhibits its extraordinary performance.



### HA Type Powered Loading Conveyor (Optional)

- Choice of 1, 1.5, or 3 meters of feeding length.
- When equipped with the powered loading conveyor, the machine will perform fully automatic cutting operation.

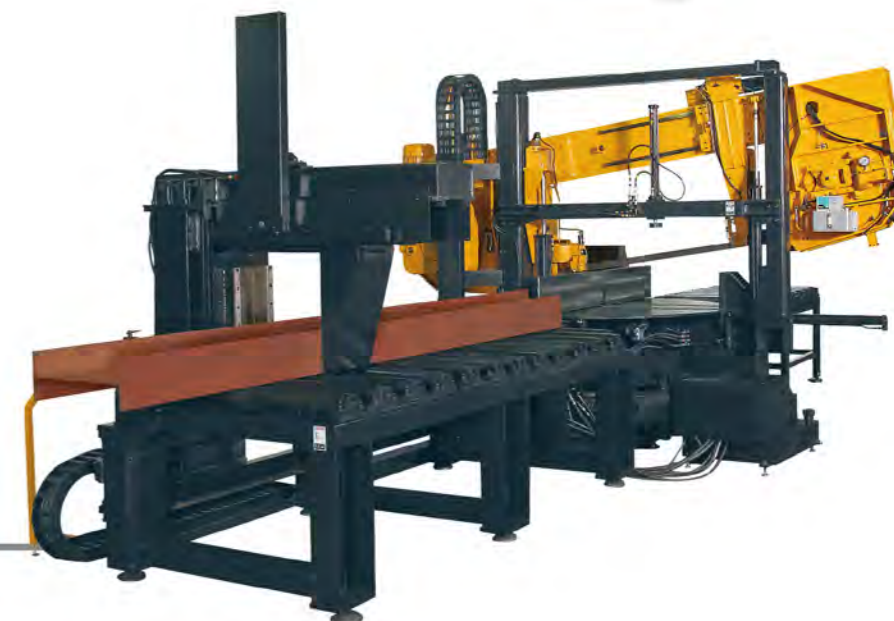





### FRAME ELEVATION CONTROLLED BY DOUBLE CYLINDERS

The frame elevation is actuated by double hydraulic cylinders extremely stable and smooth movement.



### Guide Arm with Linear Ways

The guide arm moves on linear guide ways, and moving together with vise for time saving and increased convenience of operation.



### Hold Down Device

With the hold down device, the material can be clamped securely. This may avoid material vibration during cutting.

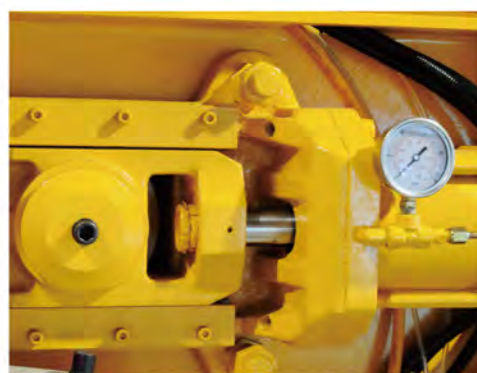

### Hydraulic Sawblade Tension Control

- The sawblade tension is controlled by hydraulic power, allowing the sawblade to maintain at a proper tension condition at all times.
- Equipped with a pressure gauge for indicating the sawblade tension. It also permits the operator to adjust the sawblade tension accurately.

### HYDRAULIC VISE

Hydraulically actuated vise provides fast and secure clamping effect.



### POWERFUL EQUIPMENT FOR AUTOMATION AND EFFICIENCY

#### Swiveling Table

- The powered table is designed with bi-directional swivel. Swiveling angle range is  $+45^{\circ} \sim 0^{\circ} \sim -60^{\circ}$ , enabling the machine to perform mitre cutting.
- The table swiveling mechanism is equipped with an encoder to ensure positioning accuracy.
- Swiveling angle can be set on the screen.



### 1 Oil Mist Cooling System

The oil mist cooling system is capable of providing sufficient lubrication during sawing, and also reducing sawing temperature, for extending the sawblade life and upgrading cutting quality.

### 2 Fast Approach Device By Photoelectric Detecting

The sawblade may fast approach to workpiece. During downfeed of sawblade, when it is sensed by a photoelectric sensor, the downfeed speed slow down automatically. This not only prevents the sawblade from bumping against the workpiece, but also saves time.

### 3 Powered Sawblade Cleaning Wire Brush

The wire brush provides continuous cleaning of sawblade, ensuring cutting smoothness and extending sawblade life.

### 4 Human-Machine Interface (Optional)

- The machine employs a PLC control in combination with touch-screen for user-friendly operation.
- Allows for setting various cutting data, such as cutting length, working jobs and angle setting, etc.



## S SERIES

## SPECIFICATION

Model		S-4633SA	S-6240SA	S-6235HA
CAPACITY	90° ● ■ (W x H)	330 mm (13") 460 x 305 mm (18.1" x 12")	400 mm (15.7") 620 x 400 mm (24.4" x 15.7")	350 mm (13.8") 620 x 350 mm (24.4" x 13.8")
	±45° ● ■ (W x H)	305 mm (12") 305 x 305 mm (12" x 12")	400 mm (15.7") 420 x 400 mm (16.5" x 15.7")	350 mm (13.8") 420 x 350 mm (16.5" x 13.8")
	-60° ● ■ (W x H)	220 mm (8.7") 250 x 220 mm (9.8" x 8.7")	300 mm (11.8") 290 x 400 mm (11.4" x 15.7")	300 mm (11.8") 290 x 350 mm (11.4" x 13.8")
BLADE SPEED		25, 45, 70, 100 m/min	20, 45, 70, 100 m/min	20 to 100 m/min
MOTOR	BLADE DRIVE	2.2 kW (3 HP)	3.7 kW (5 HP)	3.7 kW (5 HP)
	HYDRAULIC PUMP	0.4 kW (1/2 HP)	0.75 kW (1 HP)	0.75 kW (1 HP)
	COOLANT PUMP	0.1 kW (1/8 HP)	0.1 kW (1/8 HP)	0.1 kW (1/8 HP)
BLADE SIZE		4115 X 27 X 0.9 mm (162" x 1.1" x 0.035")	4900 X 34 X 1.1 mm (192.9" x 1.3" x 0.043")	4900 X 34 X 1.1 mm (192.9" x 1.3" x 0.043")
BLADE TENSION		Manual	Hydraulic	
INDEX LENGTH	SINGLE FEED			600 mm (23.6")
	MAX INDEX TIMES			9
ANGLE SWIVEL		Manual		
ANGLE DISPLAY		Angle Scale		
TABLE HEIGHT		770 mm (30.3")	830 mm (32.7")	
VISE CLAMPING TYPE		Rack type	Hydraulic (Full Stroke 2 Step)	
MACHINE WEIGHT		800 kgs (1764 lbs)	1500 kgs (3307 lbs)	2200 kgs (4850 lbs)
FLOOR SPACE (W X D)		2100 X 2050 mm (82.7" x 80.7")	2385 X 2580 mm (93.9" x 101.6")	2350 X 3400 mm (92.5" x 133.9")

\* All specifications, dimensions and design characteristics shown in this catalogue are subject to change without prior notice.

## HW SERIES

## SPECIFICATION

Model		HW450/650II	HW500/900II	HW700/1100
CAPACITY	90° ● ■ (W x H)	490 mm (19.3") 650 x 450 mm (25.6" x 17.7")	500 mm (19.7") 900 x 500 mm (35.4" x 19.7")	715 mm (28.1") 1100 x 700 mm (43.3" x 27.6")
	±45° ● ■ (W x H)	390 mm (15.4") 390 x 420 mm (15.4" x 16.5")	500 mm (19.7") 580 x 500 mm (22.8" x 19.7")	680 mm (26.8") 680 x 700 mm (26.8" x 27.6")
	-60° ● ■ (W x H)	260 mm (10.2") 260 x 420 mm (10.2" x 16.5")	375 mm (14.8") 375 x 500 mm (14.8" x 19.7")	480 mm (18.9") 480 x 700 mm (18.9" x 27.6")
MIN CLAMPING		-	150 mm (5.9")	410 mm (16.1")
BLADE SPEED		20 ~ 100 m/min	15 ~ 100 m/min	15 ~ 100 m/min
BLADE SIZE		7200 x 41 x 1.3 mm (283.5" x 1.6" x 0.05")	8300 x 54 x 1.6 mm (326.8" x 2.1" x 0.06")	9600 x 54 x 1.6 mm (378" x 2.1" x 0.06")
MOTOR	BLADE	3.7 kW (5 HP)	5.5 kW (7.5 HP)	7.5 kW (10 HP)
	HYDRAULIC PUMP	1.5 kW (2 HP)	2.2 kW (3 HP)	2.2 kW (3 HP)
	OIL MIST	0.18 kW (1/4 HP)	0.18 kW (1/4 HP)	0.18 kW (1/4 HP)
	WIRE BRUSH	0.09 kW (1/8 HP)	0.09 kW (1/8 HP)	0.09 kW (1/8 HP)
BLADE TENSION		Hydraulic		
ANGLE SWIVEL		Powerful With LED Display		
TABLE HEIGHT		890 mm (35")	900 mm (35.4")	940 mm (37")
VISE CLAMPING TYPE		Hydraulic (Full Stroke)		
MACHINE WEIGHT W/O loading conveyor		4500 kgs (9921 lbs)	5750 kgs (12677 lbs)	7000 kgs (15432 lbs)
FLOOR SPACE (W X D) W/O loading conveyor		3500 x 3200 mm (137.8" x 126")	4100 x 3650 mm (161.4" x 143.7")	4600 x 4400 mm (181.1" x 173.2")

\* All specifications, dimensions and design characteristics shown in this catalogue are subject to change without prior notice.

### SEMI AUTOMATIC S-4633SA & S-6240SA

#### STANDARD FEATURES

- Bi-direction angle swivel -60° ~ 0° ~ +45° with scale indicator.
- Blade breakage detector device
- Blade cleaning brush.
- Hydraulic flow down feed control.
- Hydraulic vise clamping
- Working light
- Roller stock table, 2M long (Except S-4633SA)
- One piece of bi-metal saw blade.
- One set of tools with tool box.

#### OPTIONAL EQUIPMENT

- Nesting fixture for bundle cutting
- Variable vise pressure
- Variable blade speed by inverter
- Roller stock table, 1.5M long (For S-4633SA)

### FULLY AUTOMATIC S-6235HA

#### STANDARD FEATURES

- Hydraulically controlled dual vise clamping system - 2 step
- Shuttle type automatic feed (only for 0° ~ -60°)
- Blade cleaning brush
- Bi-direction angle swivel -60° ~ 0° ~ +45° with scale indicator.
- Blade breakage detector device
- Automatic work height control device
- PLC control
- Working light
- Roller stock table, 2M long
- One piece of bi-metal saw blade.
- One set of tools with tool box.

#### OPTIONAL EQUIPMENT

- Automatic chip conveyor
- Nesting fixture for bundle cutting
- Variable vise pressure
- NC control

#### STANDARD FEATURES

- Double column down feed.
- Guide arm moves on linear guide way, moving with vise.
- Power table swiveling with bi-direction mitre, +45° ~ 0° ~ -60°.
- Hold down device for anti-vibration.
- Fast approach device by photoelectric detecting.
- Spray oil mist coolant system.
- Automatic chip conveyor
- Compensation valve for controlling cutting feeding

#### OPTIONAL EQUIPMENT

- Equipped with power loading conveyor single index length can be 1 meter, 1.5 meter or 3 meter.
- Automatic working system machine with power loading conveyor and HMI for input cutting data, such as cutting length, working jobs and angle setting.